

# RoadWon

The Road Won is the undisputed king of the road. Its classic geometry is designed with miles in mind - lightweight and efficient, you'll cover ground with effortless ease. Vertical compliance is coupled with torsional rigidity, resulting in a bike that is perfect for longer sportives, audax's and weekend rides.

**qoroZ**  
professional titanium bikes

www.qoroz.com  
01453 889204



*designed simply to be the best*



The Road Won is an extremely versatile package, allowing you full mudguard clearance to get you through a typical British winter, and the rear rack mounts enable the use of light panniers or rack top bags for your longer rides and fast commutes.

**Build Options:**

**Frame:** qoroz titanium frame with custom cable adjusters, cable guide and M5 bolts. RRP £1,250

**Frame Weight:** (Medium) 1250g

**Frameset:** as above, + qoroz titanium stem (90-120mm), seatpost (350mm long, 18mm layback), spacers, qoroz full carbon fork and Chris King headset. RRP £1,799

**Fork Weight:** 335g - uncut 300mm steerer tube.

**Wheels:** qC50 carbon clinchers £599  
 qT50 carbon tubulars £599

**Complete bikes start from £2,250**

We can deliver a tailored specification to suit your budget and aspirations - please contact us to discuss your needs.

Why not get an expert bike-fitting session in collaboration with Kinetic-One for a truly bespoke custom-fitted bike. Prices start at £250. Please contact us for details, and to arrange a fitting session using the latest technology.

Build prices are approximate, and include VAT.

We reserve the right to amend details and prices without prior notice.

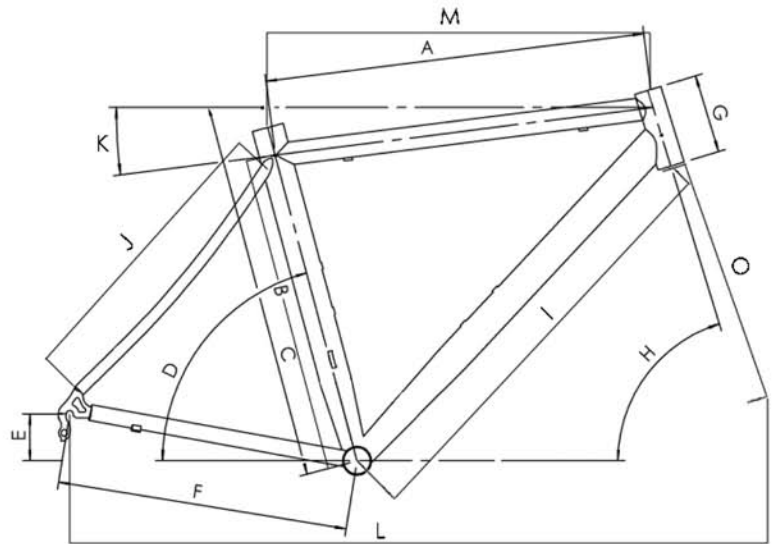

	A	B	C	D	E	F	G	H	I	J	K	L	M	O
S	489	400	520	73°	72	445	110	71°	584	447	13.5°	992	510	370
M	513	440	557	73°	70	445	150	71°	600	469	12.6°	1020	535	370
L	543	490	605	73°	68	445	200	71°	621	498	11.6°	1052	565	370
XL	575	540	631	73°	65	445	230	71°	642	532	8.8°	1085	595	370

Measurements in mm unless otherwise specified.

**Geometric Dimensions:** fork rake is 46mm and trail is 65mm. Want a XS? No problem - contact us to discuss sizing!